

Howell Pneumatic Actuators

Double Acting & Spring Return

SPECIFICATIONS:

- Modified Scotch Yoke Mechanism
 - Provides increased starting and end torque
 - High Cycle Life
 - Maintenance Free Design
- No Metal to Metal Contact
- Compact Design
- ISO 5211 Mounting for Valves
- NAMUR, VDI/VDE 3845 Mounting for Accessories
- Extended Travel Stops Available
- Hard Anodized Aluminum Body and Double Coated Interior
 - Corrosion resistance
- Maximum Operating Pressure: 150psi
- Working Temperature: -20°C to 80°C / -4°F to 176°F



ACCESSORIES:

- Solenoid Valves
 - Various NEMA Ratings & Voltages
- Limit Switches
 - Various NEMA Ratings & Voltages
- Positioners
- Speed Control Valves, Dribble Controls and other Options Available.

*Let Howell Help You Select the Right
Valve Actuation Package*



SERIES HDA DOUBLE ACTING

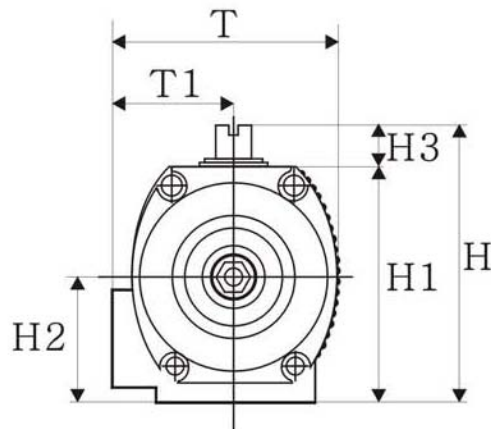
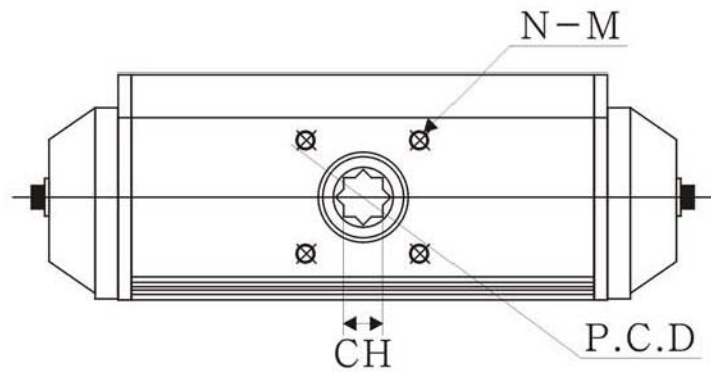
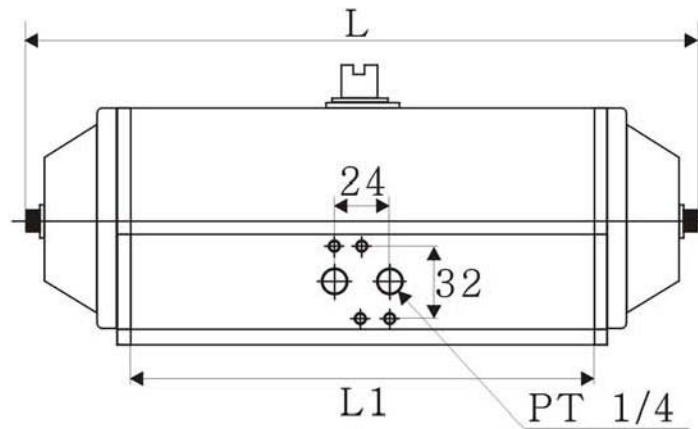
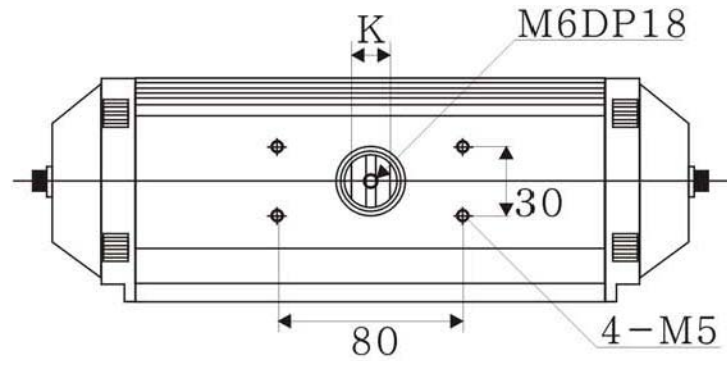



SERIES HDA DOUBLE ACTING

DIMENSIONS:

SERIES	ISO		K	DP	L	L1	CH	P.C.D.	T	TI	H	H1	H2	H3	N-M	WEIGHT	
HDA50	F03/ F05	MM	11	13	190	133	11x11	36/50	69	40	87.5	67	36	21	4-M5/M6	KG	1.6
		IN	0.43	0.51	7.48	5.24	.43x.43	1.42/1.97	2.72	1.57	3.44	2.64	1.42	0.81		LB	3.5
HDA65	F05/ F07	MM	13	17	242	166	14x14	50/70	83	46	107	86	47	21	4-M6/M8	KG	3.2
		IN	0.51	0.67	9.53	6.54	.55x.55	1.97/2.76	3.27	1.81	4.19	3.39	1.85	0.81		LB	7.1
HDA80	F07	MM	15	19	289	202	17x17	70	98	56	124	103	55	21	4-M8	KG	5.4
		IN	0.59	0.75	11.4	7.95	.67x.67	2.76	3.86	2.2	4.86	4.06	2.17	0.81		LB	12
HDA100	F07/ F10	MM	22	26	348	250	22x22	70/102	114	62	144	123	64.5	21	4-M8/M10	KG	10
		IN	0.87	1.02	13.7	9.84	.87x.87	2.76/4.02	4.49	2.44	5.65	4.84	2.54	0.81		LB	22
HDA125	F07/ F10	MM	22	26	443	305	22x22	70/102	136	68	169	148	77	21	4-M8/M10	KG	17
		IN	0.87	1.02	17.4	12	.87x.87	2.76/4.02	5.35	2.68	6.63	5.83	3.03	0.81		LB	37
HDA140	F10/ F12	MM	22	29	486	356	27x27	102/125	158	79	191	170	90	21	4-M10/M12	KG	24
		IN	0.87	1.14	19.1	14	1.06x1.06	4.02/4.92	6.22	3.11	7.52	6.69	3.54	0.83		LB	53
HDA160	F10/ F12/ F14	MM	31.8	30	560	400	27x27 36x36	102/125/140	178	86	211	190	100	21	4-M10/	KG	35
		IN	1.25	1.18	22	15.7	1.06x1.06	4.02/4.92/5.51	7.01	3.39	8.31	7.48	3.94	0.83	4-M12/	LB	77
							4-M16										

TORQUE CHART:

AIR SUPPLY

SERIES	ANGLE	40 PSI		60 PSI		80 PSI	
		AIR TO CLOSE	AIR TO OPEN	AIR TO CLOSE	AIR TO OPEN	AIR TO CLOSE	AIR TO OPEN
HDA50	0	252	182	321	243	365	356
	45	130	139	174	182	260	269
	90	217	217	286	330	434	451
HDA65	0	547	512	738	677	1,137	1,007
	45	286	330	391	425	590	634
	90	469	451	625	616	929	929
HDA80	0	1,050	911	1,423	1,241	2,265	1,823
	45	564	599	729	799	1,128	1,250
	90	842	877	1,128	1,154	1,719	1,814
HDA100	0	1,684	1,614	2,300	2,144	3,411	3,194
	45	955	1,102	1,276	1,432	2,057	2,170
	90	1,502	1,554	2,005	2,057	3,021	3,151
HDA125	0	3,715	3,750	4,999	4,782	7,699	6,892
	45	2,213	2,370	2,942	3,125	4,453	4,609
	90	3,342	3,255	4,427	4,262	6,510	6,353
HDA140	0	5,407	4,999	7,204	6,544	11,379	9,522
	45	2,890	2,873	3,906	3,949	5,998	5,798
	90	4,513	4,539	5,980	6,249	9,157	8,419
HDA160	0	8,272	7,057	9,956	9,218	15,623	13,887
	45	4,687	4,939	6,336	6,579	9,634	9,834
	90	7,638	8,497	10,155	11,457	15,189	17,594

Howell reserves the right to alter design specifications without notice



SERIES HSR SPRING RETURN

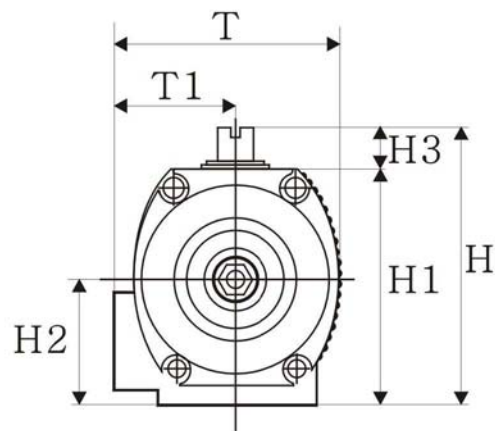
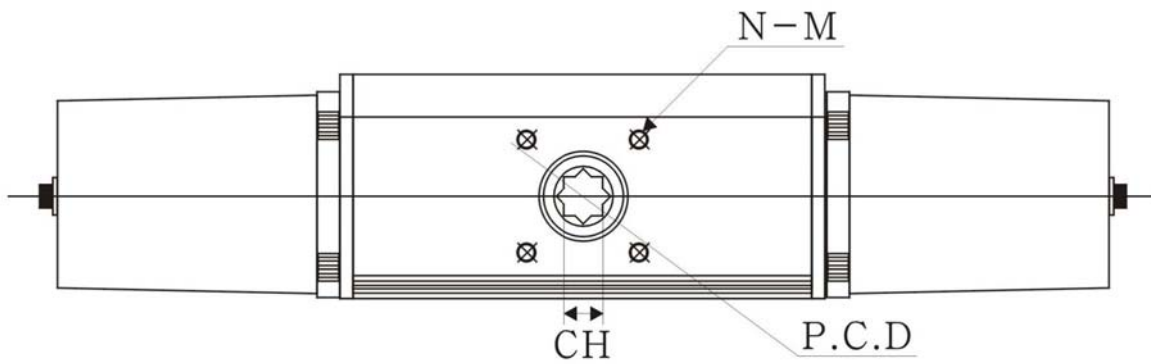
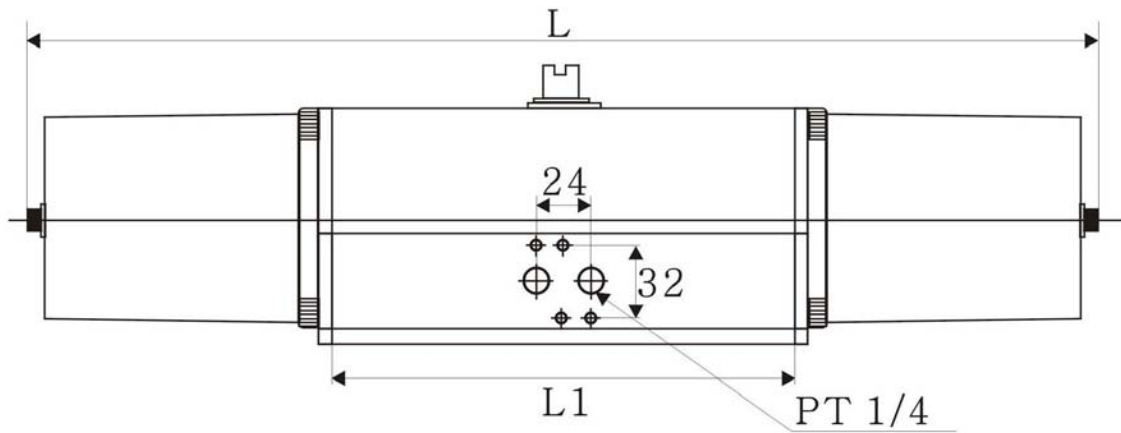
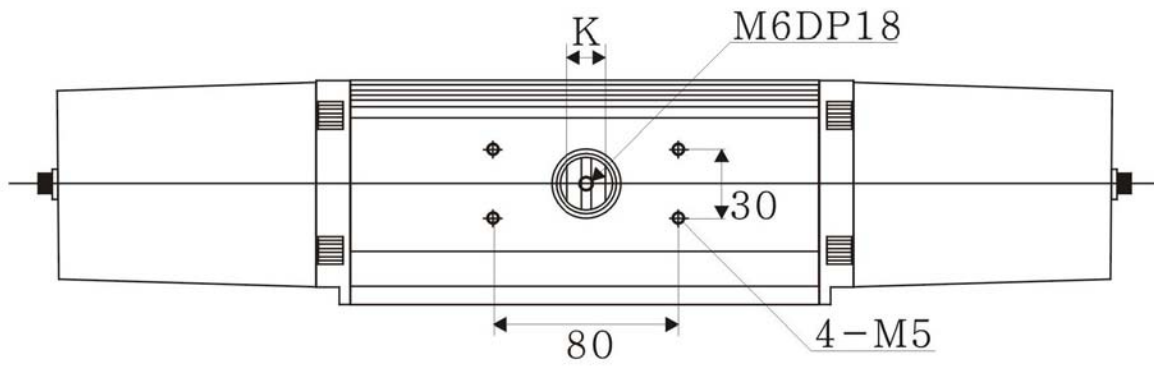



SERIES HSR SPRING RETURN

DIMENSIONS:

SERIES	ISO		K	DP	L	L1	CH	P.C.D.	T	TI	H	H1	H2	H3	N-M	WEIGHT	
HSR50	F03/ F05	MM	11	13	268	133	11x11	36/50	69	40	87.5	67	36	20.5	4-M5/M6	KG	1.6
		IN	0.43	0.51	10.6	5.24	.43x.43	1.42/1.97	2.72	1.57	3.44	2.64	1.42	0.81		LB	3.5
HSR65	F05/ F07	MM	13	17	330	166	14x14	50/70	83	46	107	86	47	20.5	4-M6/M8	KG	3.2
		IN	0.51	0.67	13	6.54	.55x.55	1.97/2.76	3.27	1.81	4.19	3.39	1.85	0.81		LB	7.1
HSR80	F07	MM	15	19	422	202	17x17	70	98	56	124	103	55	20.5	4-M8	KG	5.4
		IN	0.59	0.75	16.6	7.95	.67x.67	2.76	3.86	2.2	4.86	4.06	2.17	0.81		LB	12
HSR100	F07/ F10	MM	22	26	508	250	22x22	70/102	114	62	144	123	64.5	20.5	4-M8/M10	KG	10
		IN	0.87	1.02	20	9.84	.87x.87	2.76/4.02	4.49	2.44	5.65	4.84	2.54	0.81		LB	22
HSR125	F07/ F10	MM	22	26	640	305	22x22	70/102	136	68	169	148	77	20.5	4-M8/M10	KG	17
		IN	0.87	1.02	25.2	12	.87x.87	2.76/4.02	5.35	2.68	6.63	5.83	3.03	0.81		LB	37
HSR140	F10/ F12	MM	22	29	755	356	27x27	102/125	158	79	191	170	90	21	4-M10/M12	KG	24
		IN	0.87	1.14	29.7	14	1.06x1.06	4.02/4.92	6.22	3.11	7.52	6.69	3.54	0.83		LB	53
HSR160	F10/ F12/ F14	MM	31.8	30	850	400	27x27 36x36	102/125/140	178	86	211	190	100	21	4-M10/	KG	35
		IN	1.25	1.18	33.5	15.7	1.06x1.06	4.02/4.92/5.51	7.01	3.39	8.31	7.48	3.94	0.83	4-M12/	LB	77
							1.42x1.42								4-M16		

TORQUE CHART:

AIR SUPPLY

SERIES	ANGLE	40 PSI		60 PSI		80 PSI	
		SPRING TO CLOSE	AIR TO OPEN	SPRING TO CLOSE	AIR TO OPEN	SPRING TO CLOSE	AIR TO OPEN
HSR50	0	87	174	122	226	148	295
	45	78	78	104	104	130	130
	90	174	87	226	122	295	148
HSR65	0	191	339	304	469	417	608
	45	156	156	200	243	321	278
	90	339	191	469	304	608	417
HSR80	0	347	608	521	868	694	1,128
	45	260	260	434	434	608	608
	90	608	347	868	521	1,128	694
HSR100	0	608	1,215	868	1,649	1,128	2,083
	45	434	434	694	694	955	955
	90	1,215	608	781	868	2,083	1,128
HSR125	0	1,302	2,170	1,996	3,298	2,604	4,427
	45	1,128	1,128	1,649	1,649	2,257	2,257
	90	2,170	1,302	3,298	1,996	4,427	2,604
HSR140	0	1,736	3,211	2,604	4,774	3,559	6,336
	45	1,476	1,476	2,517	2,517	2,951	2,951
	90	3,211	1,736	4,774	2,604	6,336	3,559
HSR160	0	3,472	4,687	4,774	6,510	6,683	9,982
	45	2,517	2,517	3,645	3,645	4,861	4,861
	90	4,687	3,472	6,510	4,774	9,982	6,683

Howell reserves the right to alter design specifications without notice

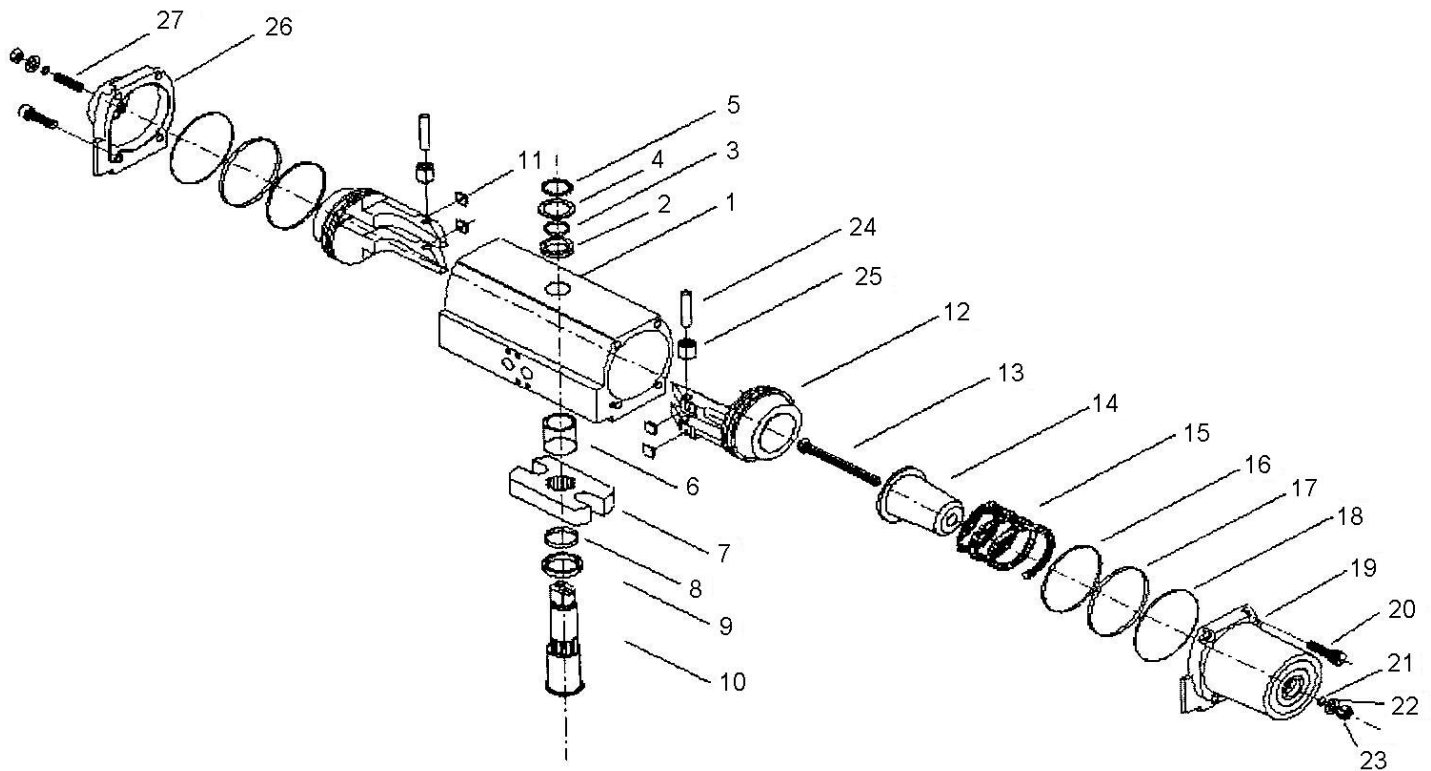

MATERIALS LIST:

Item	Part	Material
1	Body	Aluminum
2	Body Bushing (Up)	Nickel Plated Steel
3	Body O-Ring (Up)	Buna Nitrile
4	Acetal Ring	Acetal
5	Snap Ring	304 SS
6	Shaft Roller	Carbon Steel
7	Crank	Nickel Plated Steel
8	Body O-Ring (Down)	Buna Nitrile
9	Body Bushing (Down)	Nickel Plated Steel
10	Drive Shaft	Nickel Plated Steel
11	Truss Pad	Teflon
12	Piston	Aluminum
13	SA Cover Bolt	Aluminum
14	Spring Cap	304 SS

Item	Part	Material
15	Spring	SCB
16	Cover O-Ring (In)	Buna Nitrile
17	Guide Ring	Teflon
18	Piston O-Ring	Buna Nitrile
19	SA Cover	Aluminum
20	Wrench Bolt	304 SS
21	Cover O-Ring (Out)	Buna Nitrile
22	Washer	304 SS
23	Nut	304 SS
24	Piston Pin	Nickel Plated Steel
25	Piston Roller	Nickel Plated Steel
26	SD Cover	Aluminum
27	SD Set Screw	304 SS